

DETAIL "A"

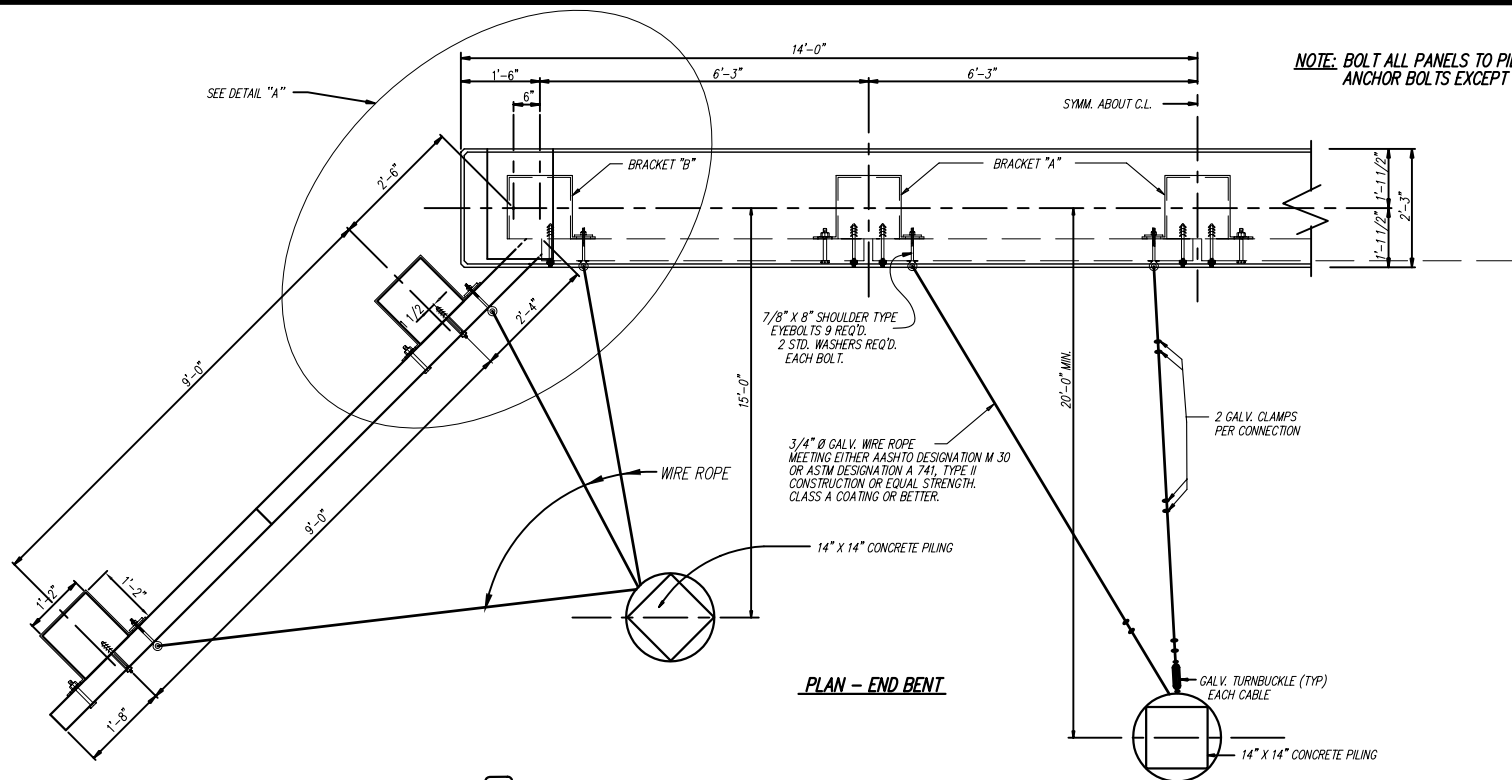

PLAN - END BENT

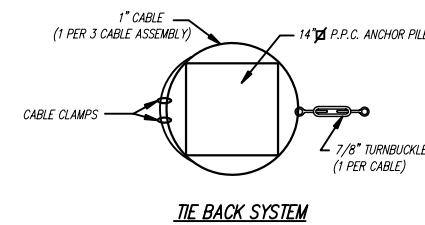

TIE BACK SYSTEM

NOTE: ONE WIRE ROPE ABUTMENT ANCHOR ASSEMBLY CONSIST OF ALL CABLE AND HARDWARE REQUIRED TO DO ONE END OF A BRIDGE. THEREFORE, THERE ARE TWO PER BRIDGE.

GENERAL NOTES

SPECIFICATIONS:
 AASHTO STANDARD SPECIFICATIONS FOR HIGHWAY BRIDGES
 AASHTO STANDARD SPECIFICATIONS FOR TRANSPORTATION MATERIALS
 AMERICAN SOCIETY FOR TESTING AND MATERIALS

CONCRETE:
 CONCRETE SHALL CONFORM TO AASHTO CLASS AE WITH A MINIMAL 28 DAY BREAKING STRENGTH OF 3000 PSI. ALL EXPOSED CORNERS SHALL BE ROUNDED TO A 1/4" RADIUS UNLESS OTHERWISE NOTED.

REINFORCING:
 ALL REINFORCING STEEL SHOULD BE ACCURATELY LOCATED IN THE FORMS AND FIRMLY HELD IN PLACE. REINFORCING STEEL SHALL MEET THE REQUIREMENTS OF THE APPROPRIATE SECTION OF AASHTO M31, AASHTO M32, AASHTO M221 OR AASHTO M225. REINFORCING DIMENSIONS ARE TO THE C/S OF BARS UNLESS OTHERWISE NOTED. THE ABOVE STEEL WILL NOT BE PAID FOR DIRECTLY, BUT WILL BE CONSIDERED AS SUBSIDIARY TO THE ITEM OF PRECAST CONCRETE ABUTMENT PANELS.

HARDWARE:
 ALL BOLTS CONNECTING CONCRETE ABUTMENT PANELS TO PILING SHALL BE CONSIDERED INCIDENTAL TO THE WORK. ALL BOLTS SHALL CONFORM TO ASTM A-307 AND BE GALVANIZED IN ACCORDANCE WITH ASTM A-153.

BID ITEMS:
 _____ PRECAST CONCRETE ABUTMENT PANELS, TYPE _____ - EACH.
 _____ PRECAST CONCRETE WING PANELS TYPE _____ - EACH.
 _____ PRECAST CONCRETE ABUTMENT WING CAP PANELS - EACH.
 _____ WIRE ROPE ABUTMENT ANCHOR ASSEMBLY - PER EACH.

DESIGN DATA:
 $f_c = 1200 \text{ PSI}$; $f_s = 24,000 \text{ PSI}$; $N = 10$

NOTE: FOR PANEL DETAILS NOT SHOWN SEE STD. DWG. NO. PCP-2400.

NOTE: BRACKET "A" IS USED AT ALL LOCATIONS WITH A CABLE CONNECTION EXCEPT THE OUTSIDE PILE ON EACH END OF THE CAP WHERE A BRACKET "B" IS USED. IF A POURED IN PLACE CAP IS USED, THE BRACKETS "A" UNDER THE CAP CAN BE ELIMINATED AND THE EYE BOLTS CAST IN THE CAP.

NOTE: FACE OF PANELS SHALL BE PERMANENTLY MARKED BY FABRICATOR FOR ERECTION.

NOTE: FILTER FABRIC SHOULD BE PLACE BETWEEN THE PANELS AND BACKFILL. ANY HORIZONTAL JOINTS WIDER THAN 1/2" MUST BE GROUTED BEFORE PLACING FABRIC. IF FILTER FABRIC IS NOT USED, THEN ALL HORIZONTAL JOINTS SHALL BE GROUTED.

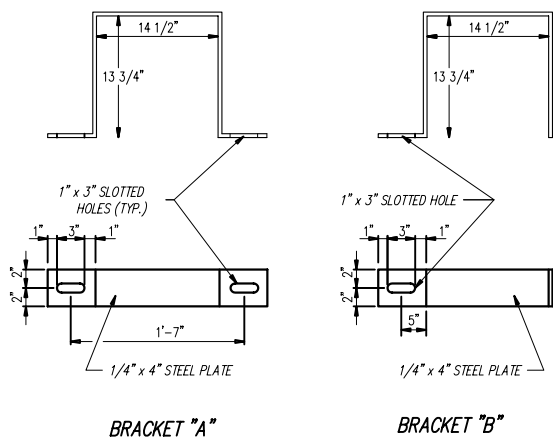

STEEL BRACKETS DETAIL

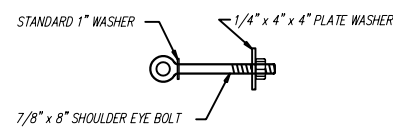

EYE BOLT DETAIL

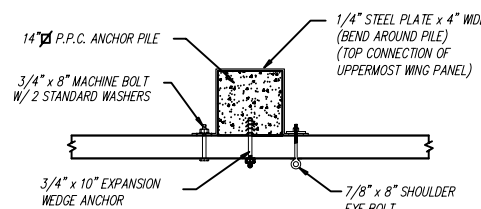

WING PANEL ASSEMBLY

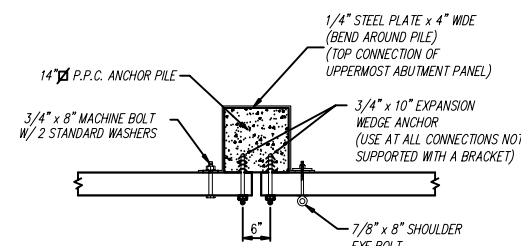

ABUTMENT PANEL ASSEMBLY

CBE CONECH BRIDGE & ENGINEERING, LLC

P. O. Box 129
 Troy, Alabama 36081

249 County Rd. 2227
 Troy, Alabama 36079

334-566-7422

**PRECAST CONCRETE ABUTMENT PANELS
 FOR USE WITH 24', 34' & 40'
 PRECAST CONCRETE SPANS
 24'-0" & 24'-6" CLEAR ROADWAY AND CONCRETE PILING**

DATE:
 7/18/03

STANDARD DWG. NO.
 PCP-2400-CP
 SHEET NO. 1 OF 1